

General Description

This 13Bit successive approximation analog to digital converter employs a charge scaling network to convert unipolar input voltages to a digital data word within 33 μ s with a resolution of 13Bit. To achieve this high accuracy and to keep test costs down, the converter is able to do a self calibration cycle for capacitor mismatch balancing. By this cycle, a correction word for every Bit is measured by a digital to analog converter having only 8Bit of resolution, which is used for error correction during normal operation.

Ratings, Parameters and Conditions

Parameter / Condition	Symbol	Min	Typ.	Max	Unit	Comment
Electrical Parameters						
Supply voltage	V_{dda}	4.75	5	5.25	V	
Operating Temperature	T_{range}	-20		85	$^{\circ}$ C	
Supply current analog	I_{dda}			3	mA	
Supply current digital	I_{dd}			2	mA	
Resolution	N		13		Bit	
Analog Ground voltage	V_{GNDA}		2.5		V	
Reference voltage	V_{ref}	1		2.5	V	measured to V_{GNDA}
Duration of conversion	T_{conv}		33		μ s	using 8MHz main clock
Duration of calibration	T_{cal}		150		μ s	using 8MHz main clock
Differential linearity error	ADC_{DNL}		$\pm 1/4$	$\pm 3/4$	LSB	after calibration cycle
Integral linearity error	ADC_{INL}			± 2	LSB	after calibration cycle
Offset error	ADC_{Off}		1	3	LSB	after calibration cycle
Absolute Maximum Ratings						
Storage Temperature	T_{range}	-40		125	$^{\circ}$ C	
Supply Voltage	V_{dd}	-0.3		7	V	
Input Voltage	V_{in}	-0.3		$V_{dd}+0.7$		
Output Voltage	V_{out}	-0.3		$V_{dd}+0.7$		

IO-Description

Interface	I/O	Function	Comment
CLK	Input	digital clock	
POR	Input	power on reset	
SOC	Input	start conv.	
CALIB	Input	start calib.	
EOC	Output	end of conv.	
Vref	Input	reference voltage	
Vin	Input	input voltage	
B_out[0..12]	Output	ADC result	
GND, GNDA, VDD	Input	voltage supply	

Symbol

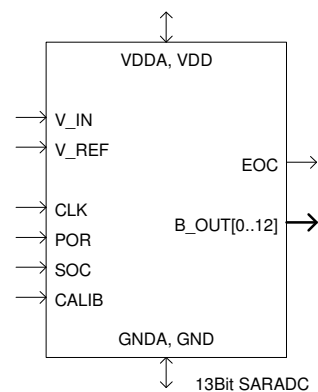

For more information please contact
PE GmbH at:
info@pe-gmbh.com

or visit our web site at:
www.pe-gmbh.com