

General Description

Creating reference voltages and currents is of major importance in nearly every mixed signal circuit for biasing and comparative purposes.

Because of the ambient temperature's impact on most of the circuit's properties, the Bandgap reference makes use of two temperature dependencies having opposite characteristic:

- a pn junction voltage having a temperature coefficient of appr. -2 mV/K
- a multiple of the temperature voltage V_t having a temperature coefficient of appr. +0.085 mV/K

Combination of both allows achieving a zero first order temperature dependency. This analog IP cell generates a reference voltage of 1.22V. Trimming is not required. Additionally, the output voltage is converted to a constant current of 10uA. This current can be used for biasing purposes (current distribution on the mixed signal ASIC). Biasing is also possible using the appropriate voltage biasing outputs causing a 10uA current flow in a 20/4 or 10/4 P or N channel MOS respectively

Ratings, Parameters and Conditions

Parameter / Condition	Symbol	Min	Typ.	Max	Unit	Comment
Electrical Parameters:						
Supply Voltage	V_{dd}	4.75	5	5.25	V	
Supply Current	I_{dd}	200	330	505	uA	
Output Voltage	V_{BGOUT}	1.21	1.22	1.235	V	
Output Current	$I_{IREF10u}$	8.5	10.4	12.5	uA	
Temp. Coeff. V_{BGOUT}	$TC_{V_{BG}}$			54	ppm/°C	
Voltage Coeff. V_{BGOUT}	$VC_{V_{BG}}$		1.6		mV/V	at typical conditions
PSRR V_{BGOUT}	$RR_{V_{BG}}$		80		dB	at typical conditions
Temp. Coeff. $I_{IREF10u}$	$TC_{I_{BG}}$			250	ppm/°C	at typical conditions
Voltage Coeff. $I_{IREF10u}$	$VC_{V_{BG}}$		144		nA/V	at typical conditions
PSRR $I_{IREF10u}$	$RR_{V_{BG}}$		43		dB	at typical conditions
P Ch. Bias Voltage	V_{PB}		$V_{dd}-1.22$		V	at typical conditions
N Ch. Bias Voltage	V_{NB}		1.178		V	at typical conditions
Absolute Maximum Ratings:						
Operating Temperature	T_{range}	-40		120	°C	
Supply Voltage	V_{dd}	-0.3		7	V	
Input Voltage	V_{in}	-0.3		$V_{dd}+0.7$		
Output Voltage	V_{out}	-0.3		$V_{dd}+0.7$		
Operating Conditions:						
Ambient Temperature	T_{amb}	-20	27	80	°C	

IO-Description

Interface	I/O	Function	Comment
VDDA	Input	Supply	
GND A	Input	Supply	
BGOUT	Output	Reference voltage	
BGPG	Output	Power good	logical HIGH when Bandgap is in stable operating point
IREF10u	Output	Reference current	
(PD)	Input	Power down	optional

Symbol / external schematic

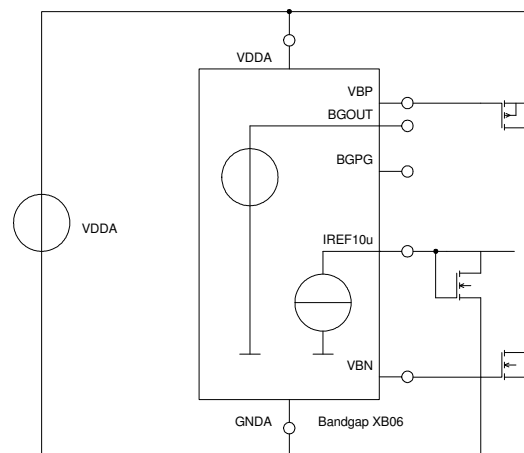

Block Diagramm

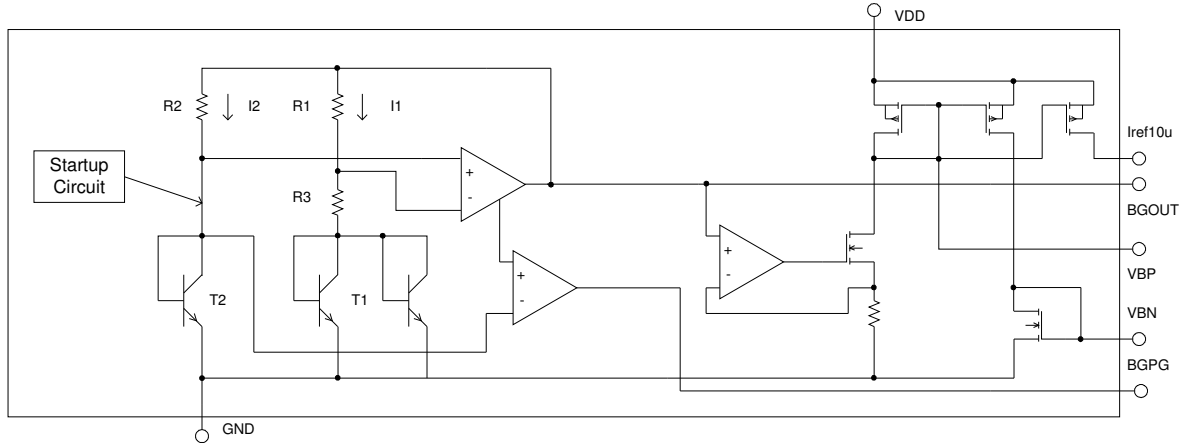

Layout Dimensions

Name	Dimensions XY	Area
BG1 XB06	500µm x 400µm	0,2µm²

Simulation Results

Output voltage versus temperature

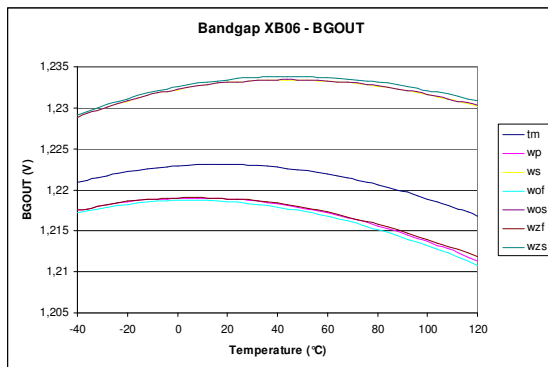

Output current versus temperature

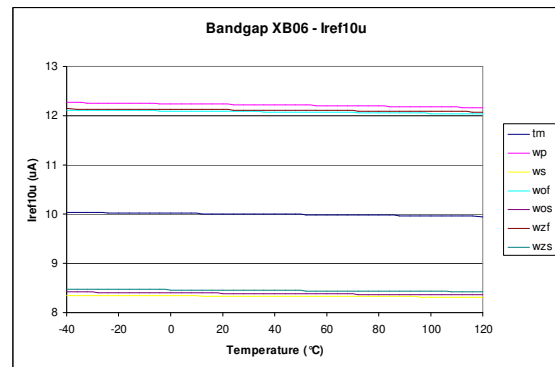

Supply current versus temperature

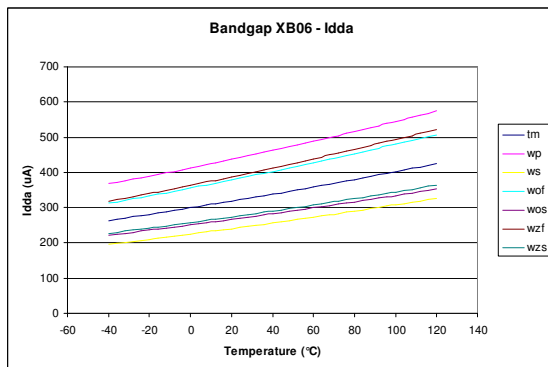

For more information please contact
PE GmbH at:
info@pe-gmbh.com

or visit our web site at:
www.pe-gmbh.com

Dieses Projekt wird im Rahmen der Technologieförderung mit
Mitteln des Europäischen Fonds für regionale Entwicklung (EFRE)
und mit Mitteln des Freistaates Sachsen gefördert.