

**Features**

- EPC Gen2 conform command structure
- UHF Gen 2 Memory Controller
- Fast data rate
- Random-Generator, WDC, CRC-Encoder/Decoder
- Interface to EEPROM up to 512 MBit
- Interfaces to user specific modules
- Modular structure for maximal flexibility
- SPI programmable

**Applications**

- active/passive RFID data acquisition
- memory based RFID TAG with flexible and permanent data structure
- automatic personalized security access control
- monitoring of product and life cycles also in medicine
- User defined RFID Data Monitoring

**General Description**

This IP-Cell is part of the RFID Sensor and Data Monitoring Solution. The main task is to support the EPCglobal Class1 Generation2 UHF RFID protocol. All internal functions are defined in flexible structures. First internal tasks are data transfer, second tasks are command transfer for user defined applications to monitoring sensor signals. The IP-Cell is usable for passive or active RFID Tags due to the flexible modular design. It features a random number generator, cyclic redundancy check encoder/decoder, watchdog counter and memory controller/handler for multi access. Most of the functionality is programmable through the SPI and can be adjusted to fit different system configurations, sensor calibrations and full memory communication.

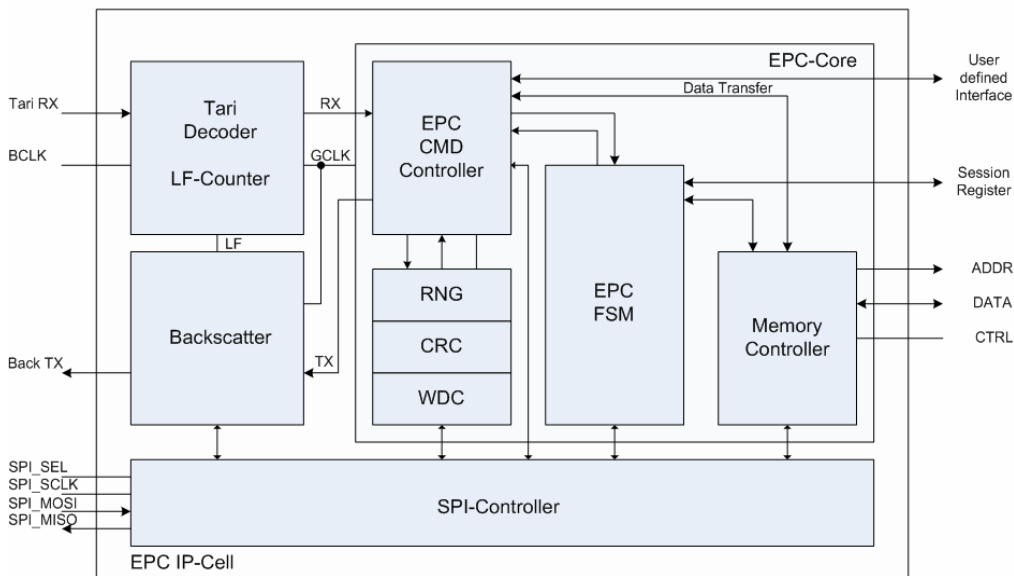

Figure 1: Block diagram EPC IP-Cell

Parameter	Symbol	Min	Typ	Max	Unit	Notes
Storage Temp.	T <sub>STOR</sub>	-40		85	°C	
Operating Temp.	T <sub>AMB</sub>	-20		50	°C	
RF Frequency	F <sub>RF</sub>	860		960	MHz	
RF digital voltage	V <sub>RFD</sub>	1.1	1.2	1.3	V	Technology dependent
Supply current	I <sub>dd</sub> + I <sub>dda</sub>			25	µA	
Frequency dig. Core (Base)	BCLK	1.20	1.28	1.96	MHz	
Frequency dig. Core (CMD)	GCLK		320		kHz	Generated from BCLK
Link Frequency	LF	40		640	kHz	RFID Reader programmable
SPI-Frequency	SPI_SCLK	0.1	1.0	2.0	MHz	

Table 1: Typical Parameters