

General Description

The CSMC Macro Standard Cell is essential element for high frequency stimulated, capacitive sensor based sensor or data acquisition systems. It's main purpose is the measure capacitances in the Femtofarad range at convert the result into the digital domain. The Input and Output ports are defined in a way, that systems with 1 to 100 inputs are feasible. Digital control and sensor stimulus generation are not included in the cell and have to be added to give a complete data acquisition system.

Ratings, Parameters and Conditions

Parameter / Condition	Symbol	Min	Typ.	Max	Unit	Comment
Electrical Parameters:						
Supply Voltage	V_{dd}	4.75	5	5.25	V	
Supply Current	I_{dd}		800		μA	digital part not included
Input Resistance	R_{in}	40	50	60	kOhm	
DC Input Voltage	V_{sdc}	2.3	2.5	2.7	V	
GAIN	GAIN		56		MOhm	V_{out}/I_{in}
Input Amplitude	V_{AOSZ}	100	150	200	mV	
AD Converter Input Voltage	V_{INREF}	0.5		4.5	V	
Settling Time	T_{start}			80	μs	
AD Converter Bit Time	T_{bit}			135	ns	
Serial Clock Frequency	T_{ser}			7,3728	MHz	
Low Pass Cut Off Frequency	F_{filt}		100		kHz	
Bandwidth I/U Converter	$BW_{I/Uconv}$	10			MHz	
Phase Shifter Granularity	D_{PHAS}	2	3	4	ns	$F_{osz}=1 \dots 10\text{MHz}$
Absolute Maximum Ratings:						
Operating Temperature	T_{range}	-20		80	$^{\circ}\text{C}$	
Supply Voltage	V_{dd}	-0.3		7	V	
Input Voltage	V_{in}	-0.3		$V_{dd}+0.7$		
Output Voltage	V_{out}	-0.3		$V_{dd}+0.7$		
Operating Conditions:						
Ambient Temperature	T_{amb}	-20	27	80	$^{\circ}\text{C}$	

IO-Description

Interface	I/O	Function	Comment
GNDa, VDDA, VCC	Input	Supply	
VBN, VBPr	Input	biasing	
SDC	Input	reference potential	
OSZPHP, OSZPHN	Input	phase shifted clock signals	from phase shifter
gMSB, gLSB	Input	gain control ports	
MXZ	Input	sensing input	
Vref	Input	voltage reference for AD conversion	
Reset	Input	data latch reset	
Test	Input	test enable	
PCO10	Input	test voltage selector	
TSTA	Output	test voltage output	
Stop	Output	comparator output	used to stop counter in digital core

Symbol / external schematic

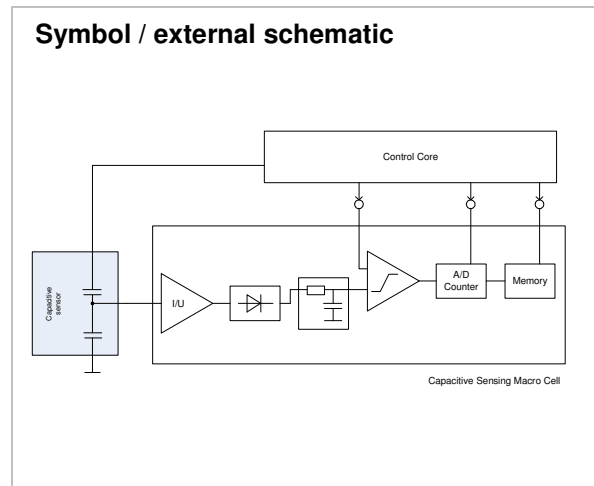

For more information please contact
PE GmbH at:
info@pe-gmbh.com

or visit our web site at:
www.pe-gmbh.com

Dieses Projekt wird im Rahmen der Technologieförderung mit Mitteln des Europäischen Fonds für regionale Entwicklung (EFRE) und mit Mitteln des Freistaates Sachsen gefördert.