

Analog IP Cell
8Bit Analog Digital Converter
FlashADC8 XH035

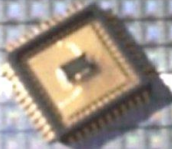

General Description

This two-stage Flash analog to digital converter transforms input voltages to a digital data word within 13 clock cycles at very low power at a resolution of 8Bit.

Ratings, Parameters and Conditions

Parameter / Condition	Symbol	Min	Typ.	Max	Unit	Comment
Electrical Parameters						
Supply voltage	V _{dd}	3.0	3.3	3.6	V	
Operating Temperature	T _{range}	-40		120	°C	
Supply current	I _{dda}		600		µA	at 20MHz, 1µA in PowerDown Mode
Resolution	N		8		Bit	
Reference voltage	V _{ref}	2		VDD	V	
Input voltage	V _{IN}	0		VDD	V	
Clock Frequency	f _{clk}	1	20		MHz	
Settling Time	T _{set}		7			Clock cycles
Duration of conversion	T _{conv}		13			Clock cycles
Differential linearity error	ADC _{DNL}			±0.5	LSB	
Integral linearity error	ADC _{INL}			±0.5	LSB	
Input offset	offset			±1	LSB	

IO-Description

Interface	I/O	Function	Comment
CLK	Input	digital clock	
POR	Input	power on reset	
PD	Input	PowerDown	
SOC	Input	Start of conversion	
EOC	Output	end of conversion	
Vref	Input	reference voltage	
Vin	Input	input voltage	
Out[7..0]	Output	ADC result	
GND, GNDA, VDD	Input	voltage supply	

Symbol

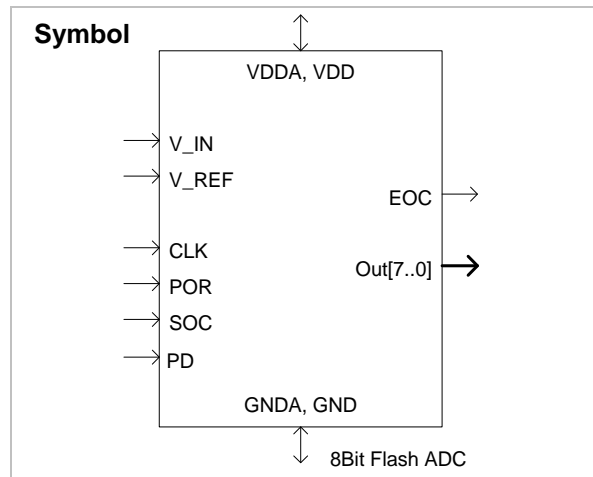

For more information please contact
 PE GmbH at:
info@pe-gmbh.com

or visit our web site at:
www.pe-gmbh.com