



General Description

The cell PreRef XC06 is a high voltage Bandgap reference source generating a reference voltage and some additional reference currents for analogue circuit biasing. The cell's speciality is its extremely low power consumption and high supply voltage ability.

The features allow the use the cell as high voltage start-up and stand-by reference for wide input range integrated circuits. A possible scenario is the integration of the cell in a switch mode power supply control IC that is able to start-up from the mains input voltage by a resistor. An additional follower voltage is generated to supply other low voltage cells inside the ASIC until the integrated voltage regulator has started up.

Ratings, Parameters and Conditions

Parameter / Condition	Symbol	Min	Typ.	Max	Unit	Comment
Electrical Parameters:						
Supply Voltage	V_{dd}	8	12	25	V	
Active Supply Current	I_{dd}		500	750	nA	
Reference Voltage	V_{ref}	1.20	1.22	1.23	V	@ $V_{dd} = 12V$
Follower Voltage	V_{fol}		2.4		V	
P Bias Voltage	V_{BP}		$V_{dd} - 896$		mV	@ typical conditions
P Cascode Voltage	V_{CASP}		$V_{dd} - 1050$		mV	@ typical conditions
Supply Voltage Rejection Ratio Reference Voltage	RRV_{ref}		68		dB	@ 1000Hz
Absolute Maximum Ratings:						
Operating Temperature	T_{range}	-40		140	°C	
Supply Voltage	V_{dd}	-0.3		25	V	
Input Voltage	V_{in}	-0.3		$V_{dd} + 0.7$		
Output Voltage	V_{out}	-0.3		$V_{dd} + 0.7$		
Operating Conditions:						
Ambient Temperature	T_{amb}	-20	27	80	°C	

IO-Description

Interface	I/O	Function	Comment
VSS	input	Supply	
VSS	Input	Supply	
NSTARTUP	Input	StandBy	
VFOL	Output	Auxiliary Supply	
VREF	Output	Reference	
VBP	Output	Reference	
VCASP	Output	Reference	

Block schematic, ext. component diagram

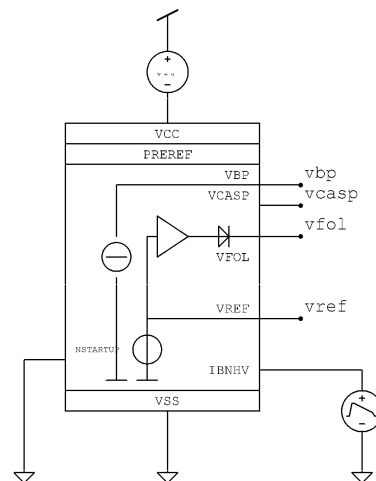

For more information please contact
 PE GmbH at:
info@pe-gmbh.com

or visit our web site at:
www.pe-gmbh.com

Dieses Projekt wird im Rahmen der Technologieförderung mit Mitteln des Europäischen Fonds für regionale Entwicklung (EFRE) und mit Mitteln des Freistaates Sachsen gefördert.