

## General Description

The Realtime Clock analogue IP cell is a power optimized clock generator intended to be used in single battery cell powered watch applications. The cell comprises of the actual oscillator stage and a sinusoidal to square wave converter for digital clock generation.

For ensuring highest accuracy of the generated output frequency and to minimize the consumed power to the lowest possible level, the circuit uses an amplitude regulation loop to limit the amplitude of oscillation to a value of appr. 230mV.

## Ratings, Parameters and Conditions

Parameter / Condition	Symbol	Min	Typ.	Max	Unit	Comment
<b>Electrical Parameters:</b>						
Supply Voltage	$V_{dd}$	1.3	1.55	1.6	V	single cell
Active Supply Current	$I_{dd}$	105	160	400	nA	after final amplitude of oscillation is reached
Start Up Time	$T_{SU}$	300	650	2000	ms	depending on quartz quality factor and temperature
Oscillation Amplitude	$V_{OSC}$	100	230	300	mV	after start up
Frequency Accuracy			15		ppm	depending on quartz
Output Frequency	$F_{CLK}$		32768		Hz	depending on quartz; divider stages can derive 1s clock for watch applications
<b>Absolute Maximum Ratings:</b>						
Operating Temperature	$T_{range}$	-40		140	°C	
Supply Voltage	$V_{dd}$	-0.3		6	V	
Input Voltage	$V_{in}$	-0.3		$V_{dd}+0.7$		
Output Voltage	$V_{out}$	-0.3		$V_{dd}+0.7$		
<b>Operating Conditions:</b>						
Ambient Temperature	$T_{amb}$	-20	27	80	°C	

## IO-Description

Interface	I/O	Function	Comment
GNDA	input	Supply	
VDDA	Input	Supply	
XTIN	InOut	Quartz	
XTOUT	InOut	Quartz	
VBP	Output	Bias Voltage	
CLK_O	Output	Clock Output	

## Block schematic, ext. component diagram

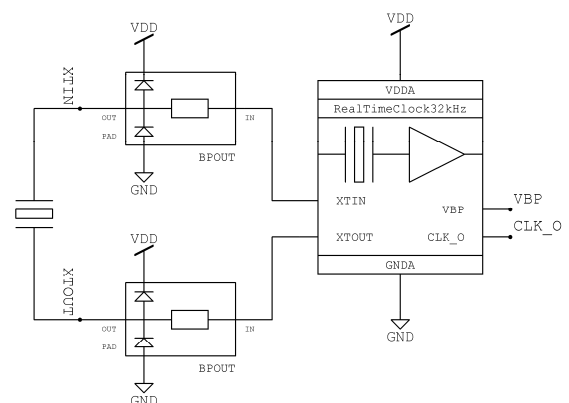

For more information please contact  
PE GmbH at:  
info@pe-gmbh.com

or visit our web site at:  
www.pe-gmbh.com

Dieses Projekt wird im Rahmen der Technologieförderung mit Mitteln des Europäischen Fonds für regionale Entwicklung (EFRE) und mit Mitteln des Freistaates Sachsen gefördert.