



Features

- Wide Input Range
- Low Total Harmonic Distortion (THD)
- Low Start Up Current (<math><5\mu A</math>)
- Low Operating Current (<math><550\mu A</math>)
- Disable Function (<math><100\mu A</math>)
- Under-Voltage Lockout with >8V Hysteresis
- Over voltage protection, Peak current protection and
- Open loop protection with separate integrated reference
- low Peak current protection threshold
- Operating Frequency from 32 kHz to 350kHz, dependent on load
- High Efficiency at high and low Output Power
- Internal Clamping Resistor at Driver
- Soft start
- fast Driver Switch 'off'

Applications

- Active power factor correction
- Switch mode power supplies

General Description

The PE4302 is a high precision wide input range controller IC for active power factor correction converters. It saves system cost due to the integrated highly accurate reference.

The IC operates in the CCM with average current control. The switching frequency depends upon the load. At high output the load frequency is low and with low load the frequency increases. The compensation for voltage loop and soft start is external. The PE4302 provides many protection functions, such as over voltage protection for output voltage and for supply voltage, open loop protection, supply under voltage lock-out, output under voltage protection and peak current limit protection. These protection functions work with separate internal references for even higher security. If an error in the regulation reference occurs, the protection function becomes operational. The soft start function limits start up current and stress on the boost diode.

When the disable function is activated, the current consumption drops below 150µA.

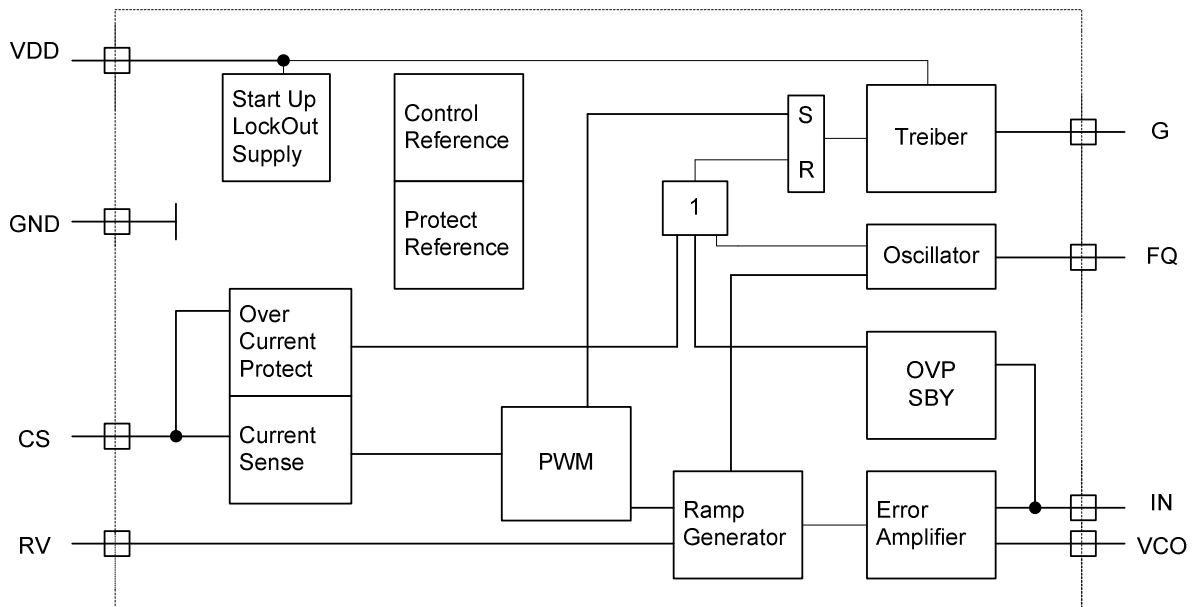

Figure 1: Block diagram

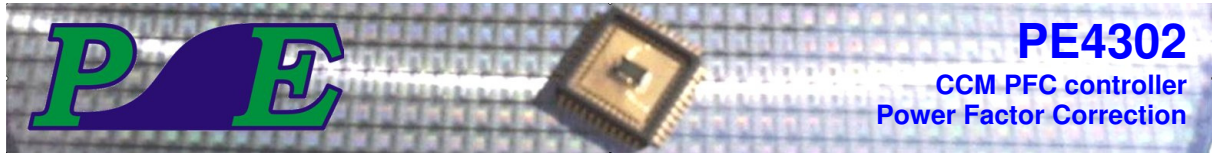
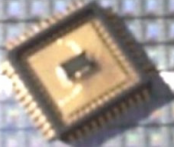

Table of Contents

General Description	1
Table of Contents	2
1 Ratings	3
1.1 Absolute Maximum Ratings	3
1.2 Operating Conditions	3
1.3 Detailed Electrical Ratings	3
2 Functional Description	5
2.1 General.....	5
2.2 Typical Application Circuit	5
2.3 Power Supply Startup behaviour	6
2.4 Gate driver behaviour.....	6
2.5 Fault Protection	7
2.6 Soft start	8
2.7 Current control	8
2.8 Average voltage control	8
2.9 Ramp generator and PWM	9
3 Interfaces	10
4 Package	10
Contact Addresses	11

PE4302

CCM PFC controller
Power Factor Correction



1 Ratings

1.1 Absolute Maximum Ratings

Parameter	Symbol	Min	Typ	Max	Unit	Notes
Operating Temp	$T_{junction}$	-40		125	°C	
Supply voltage	V_{DD}	-0.3		30	V	
Input voltage	V_{IN}	-0.3		$V_{DD}+0.7$		
Output voltage	V_{OUT}	-0.3		$V_{DD}+0.7$		
Input current	I_{IN}			10	μA	

Stresses exceeding maximum ratings may damage the device. Maximum ratings are stress ratings only. Functional operation above the recommended operating conditions is not implied. Extended exposure to stresses above the recommended operating conditions may affect device reliability.

1.2 Operating Conditions

Parameter	Symbol	Min	Typ	Max	Unit	Notes
Operating Temp	$T_{junction}$	-40	27	125	°C	
Supply voltage	V_{DD}	8	14	25	V	

1.3 Detailed Electrical Ratings

Static Operating Conditions ($T_{junction} = -40 \dots 125 \text{ °C}$; StartUp and Supply):

Parameter	Symbol	Min	Typ	Max	Unit	Notes
Start Up Voltage	V_{ST}	16	20	23	V	
Lock Out Voltage	V_{LO}	7	7,4	8	V	
StartUp/LockOut Hysteresis	V_{STLOHY}	11		16	V	
Supply current	I_{DD}		2	5	μA	before StartUp, $V_{DD} < 14V$
		180	300	550	μA	aktiv Operation, without driver load
		30	60	100	μA	aktiv and disable $V_{IN}=0.3V$
VDD over voltage protection	V_{DDOVP}	23		31	V	
Voltage at FQ Pin	V_{FQ}	0.995	1.030	1.045	V	$R_{FQ} = 100K\Omega$, $T=0$ to 50 °C , will be adjusted
		0.965	1.030	1.045	V	$R_{FQ} = 100K\Omega$, $T=0$ to 80 °C , will be adjusted

Static Operating Conditions ($T_{junction} = -40 \dots 125 \text{ °C}$; $V_{DD}=14V$, Protection Function):

Parameter	Symbol	Min	Typ	Max	Unit	Notes
Open Loop Protection / Enable (OLP), V_{IN} Threshold	V_{INOLP}	0.29	0,33	0.36	V	
Open Loop Protection / Enable (OLP), V_{IN} Hysteresis	HY_{NOLP}	70	80	100	mV	
Output Over Voltage Protection, V_{IN} Threshold	V_{INOVP}	2.64	2,70	2.75	V	
Output Over Voltage Protection, V_{IN} Hysteresis	HY_{INOVP}	70	80	100	mV	
Peak Current Protection V_{CS} Threshold	V_{CSPCP}	-1.0	-0.9	- 0.7	V	
CS Input current	I_{CS}	-20	-9	-4	μA	$V_{CS} = -0.4V$

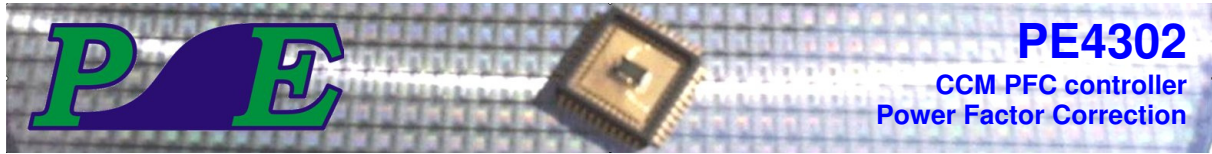

Static Electrical Characteristics: Current Loop (VDD = 14V T_{junction}= -40 to 125 °C)

Parameter	Symbol	Min	Typ	Max	Unit	Notes
CS Gain	G _{CS}	-7.9	-8	-8.1		
Input Offset Voltage	V _{OFFCS}		1	3	mV	
Input resistor	R _{CS}	60	64	113	kΩ	

Static Electrical Characteristics: Voltage Loop(VDD = 14V T_{junction}= -14 to 125 °C)

Parameter	Symbol	Min	Typ	Max	Unit	Notes
OTA Referenz Voltage	V _{INREF}	2.50	2.58	2.65	V	
OTA Gain	G _{mOTA}	90	140	190	μS	
OTA linear Range	I _{OTA}	-12		12	μA	V _{IN} = V _{INREF} ± 0.13V, V _{VCO} = 2.5V
Output high voltage	V _{OTAOH}	4.4			V	V _{IN} = 0.5V
Output low voltage	V _{OTAOL}			0.4	V	V _{IN} = 4.5V
Input current V _{IN}	I _{IN}	-0.1		0.1	μA	
Max Output current ±	I _{OTAmx}	16	40	100	μA	

Static Electrical Characteristics: Driver (VDD = 18V T_{junction}= -40 to 125 °C)

Parameter	Symbol	Min	Typ	Max	Unit	Notes
Output Voltage High	V _{GH}	7,5	8.5	10	V	I _{OH} = -50mA
Output Voltage Low	V _{GL}	1,2	1.5	2.2	V	I _{OL} = 200mA
Maximum Output Voltage	V _{GMAX}	8,0	8,5	11	V	
Output Voltage before StartUp and after LockOut	V _{GST}			1	V	
Clamping Resistor	R _G	15	21	27	KΩ	

Dynamical Operating Conditions (VDD = 14V, T_{junction}= -40 to 125 °C):

Parameter	Symbol	Min	Typ	Max	Unit	Notes
Driver rise time	t _{Gr}	10		110	ns	C _G = 1nF, V _G rise from 2V to 7V
Driver fall time	t _{Gf}	10		55	ns	C _G = 1nF, V _G fall from 7V to 2V
Peak Current Protection delay	t _{CSPCP}	150		400	ns	
Oscillator Frequency	F _{OSZ}	50		80	kHz	R _{FQ} =100KΩ, V _{VCO} =2.5V
Min Oscillator Frequency	F _{OSZmin}	32		43	kHz	R _{FQ} =100KΩ, V _{VCO} =4.5V
Max Oscillator Frequency	F _{OSZmax}	230		350	kHz	R _{FQ} =100KΩ, V _{VCO} =0.5V
Max Duty Cycle	D _{MAX}	92		99	%	V _{VIN} =2.0V, V _{CS} =0V
Min Duty Cycle	D _{MIN}			0	%	V _{VIN} =2.0V, V _{CS} =-0.6V
Duty Cycle at V _{VIN} =2.0V, V _{CS} =-0.2V		50		64	%	without resistor at RV
		52		64	%	R _{RV} = 100kΩ
Min 'off' time	t _{OFF}	150		350	ns	V _{CS} =0V

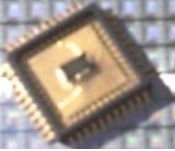

2 Functional Description

2.1 General

The PE4302 is an 8-pin analog controller IC for power factor correction converters. It is suitable for wide range line input applications from 85 to 265 VAC. The IC supports converter in boost topology and it operates in continuous conduction mode (CCM) with peak current control. The IC operates with two loops, an inner current loop and an outer voltage loop. The inner current loop is fast, reliable and does not require sensing of the input voltage in order to create a current reference. This inner current loop sustains the sinusoidal profile of the average input current based on the dependency of PWM duty cycle on the line input voltage to determine the corresponding input current. The outer voltage loop controls the DC output voltage. This voltage is fed into the voltage error amplifier to control the amplitude of the average input current. The two loops combine to control the amplitude, phase and shape of the input current, with respect to the input voltage, giving near-unity power factor. For a better regulation range, the operating frequency is modulated with the voltage loop. If the load is low and the input voltage high, the frequency increases; if the load is high and the input voltage is low, the frequency decreases. The IC is equipped with various protection features to ensure safe operating condition for the system and the device.

2.2 Typical Application Circuit

Figure 2 gives an impression about the external components required for a typical application environment.

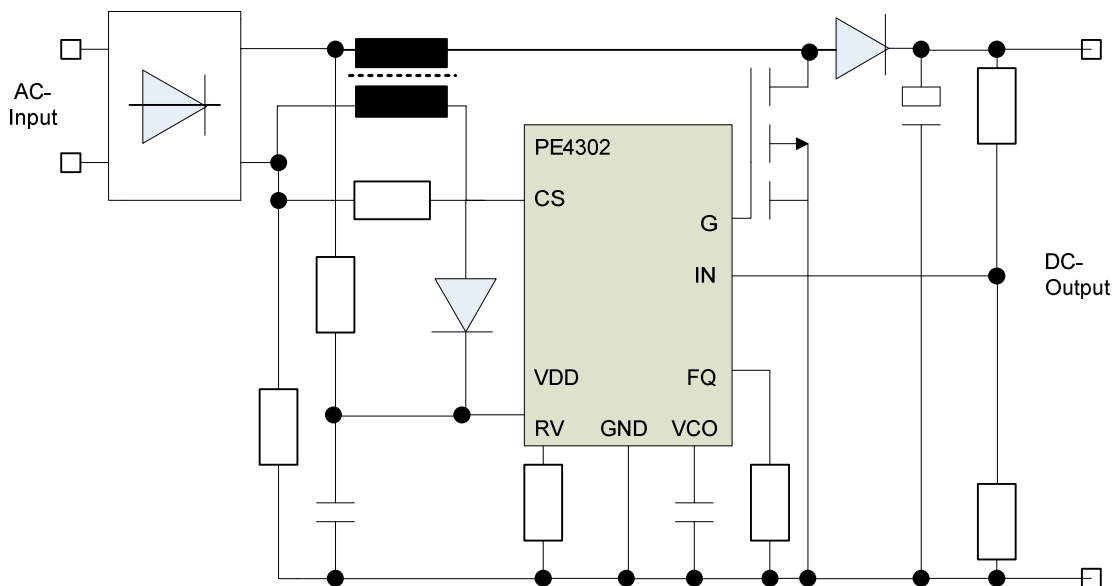

Figure 2: External component schematic

2.3 Power Supply Startup behaviour

The start-up and under voltage lockout circuit monitors VDD. If VDD rises over the start-up voltage, the system starts normal operation. If VDD falls below the lockout voltage the system turns off. The IC can be turned off and forced into standby mode by pulling down the voltage at pin IN below the OLP threshold voltage level.

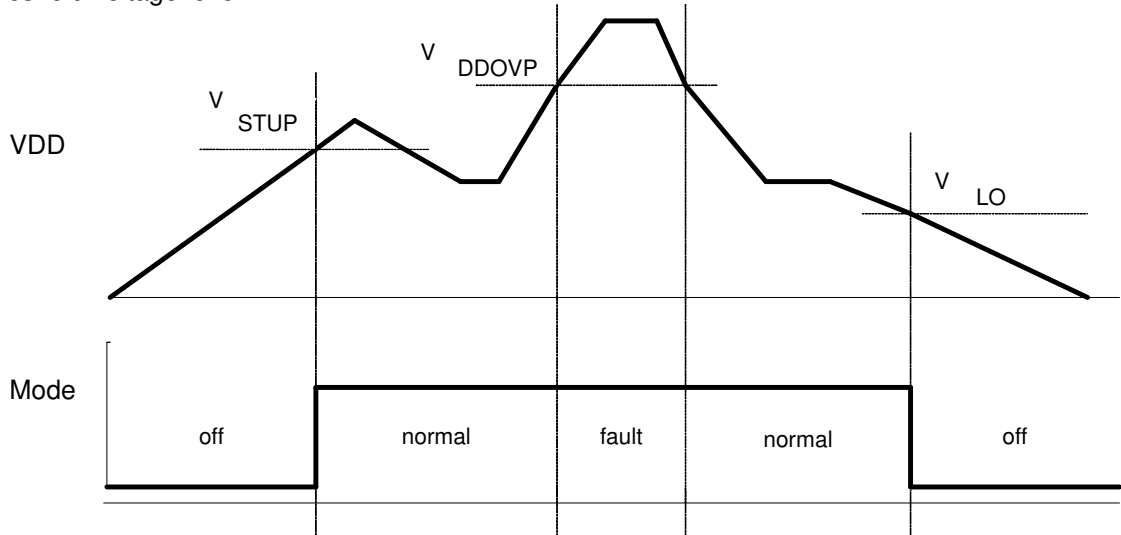

Figure 3: Startup and shut down sequence

2.4 Gate driver behaviour

The gate driver is a totem pole driver, designed for direct drive of external power MOSFET`s. The high output is clamped at V_{GMAX} .

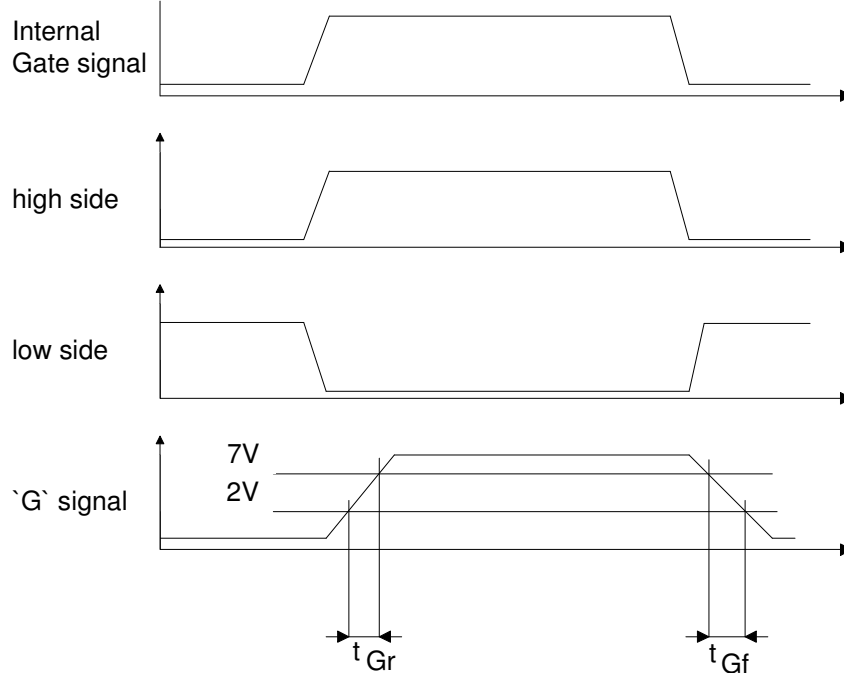
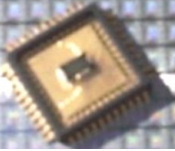

Figure 4: t_{Gr} and t_{Gf} represent the rise and fall time for the gate driver output assuming a capacitive load of 1nF



2.5 Fault Protection

The fault mode will be activated, when any of the protection circuits crosses the threshold. In fault mode the driver turns “off” or/and the duty cycle is reduced. The IC automatically resumes operation, when the protection circuits return above the threshold level.

1. Output over voltage protection (OOVP) is activated when the voltage at Pin IN rises above V_{INOVP} (figure 5).
2. Open loop protection (OLP) is activated when the voltage at pin IN falls below V_{INOLP} , or there is an insufficient input voltage for normal operation. This function can be used for external disable of the IC (figure 6).
3. Peak current limit protection (PCLP) is activated, when the voltage at pin CS drops below V_{CSPCP} . Short impulses, <300ns, are suppressed with the leading edge time. The driver turns off very fast (t_{sc}) (figure 7).
4. VDD over voltage protection (VDDOVP) is activated, when the voltage at Pin VDD increases to V_{VDDOVP} .

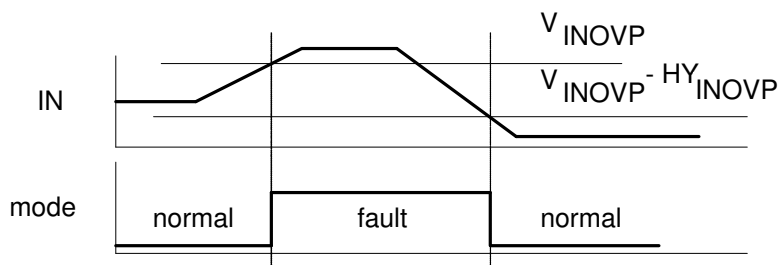

Figure 5: Output over voltage Protection

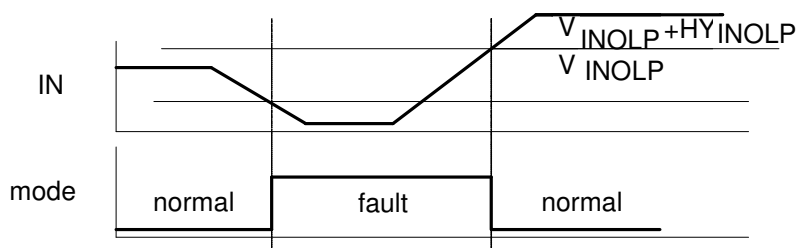

Figure 6: Output Open Loop Protection

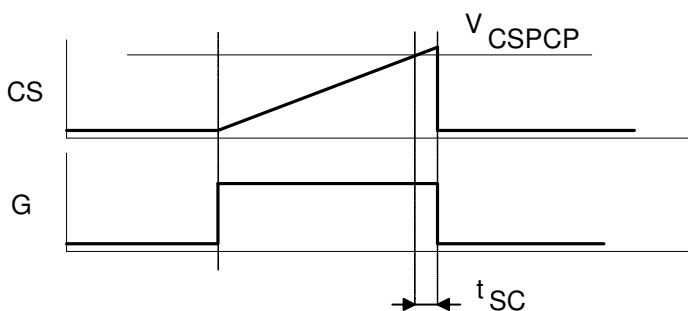

Figure 7: Peak current limit protection

2.6 Soft start

The soft start function can be realised with the capacitor at pin VCO. The output current of the voltage loop OTA and the capacitor generates a slowly ramp up for the voltage at pin VCO. With this ramp the duty cycle goes from minimal to nominal value.

Soft start time is determined by the following equation:

$$t_{ss} = \frac{C_{VCO} \cdot V_{VCO (eff)}}{I_{OTAMax}}$$

2.7 Current control

The current loop block is monitoring the voltage at pin CS, resulted from the inductor current flow through the current sense resistor. The amplifier with a gain of -8, generates the current comparator signal for the PWM block.

2.8 Average voltage control

The voltage loop block senses the feedback voltage at pin IN. The compensation for the voltage loop is connected to pin VCO. The error voltage at pin VCO is the base for the voltage comparator signal.

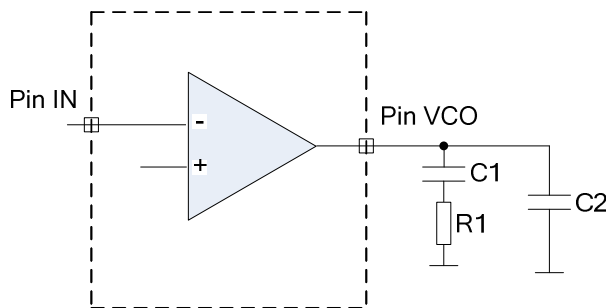

Figure 8: compensation schematic

Transfer function:

Zero:

$$f_{zo} = \frac{1}{(2 \cdot \pi \cdot R1 \cdot C1)}$$

Pole:

$$f_{po} = \frac{1}{2 \cdot \pi \cdot R1 \cdot \frac{C1 \cdot C2}{C1 + C2}}$$

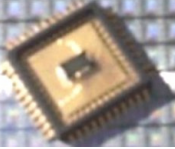

2.9 Ramp generator and PWM

The PWM block includes two ramp generators - one for the duty cycle and one for the switching frequency. If the duty cycle ramp crosses the current comparator signal from the current control, the driver turns off. If the switching frequency ramp crosses the oscillator comparator signal from the oscillator, the driver turns on.

The slew rate of the frequency ramp is defined by the resistor at pin FQ. The slew rate of the duty cycle ramp is calculated from the voltage comparator signal and an internal resistor. For higher accuracy calculation, it is possible to use a resistor at pin RV to adjust the slew rate of the duty cycle ramp. The oscillator comparator signal is calculated from the voltage comparator signal.

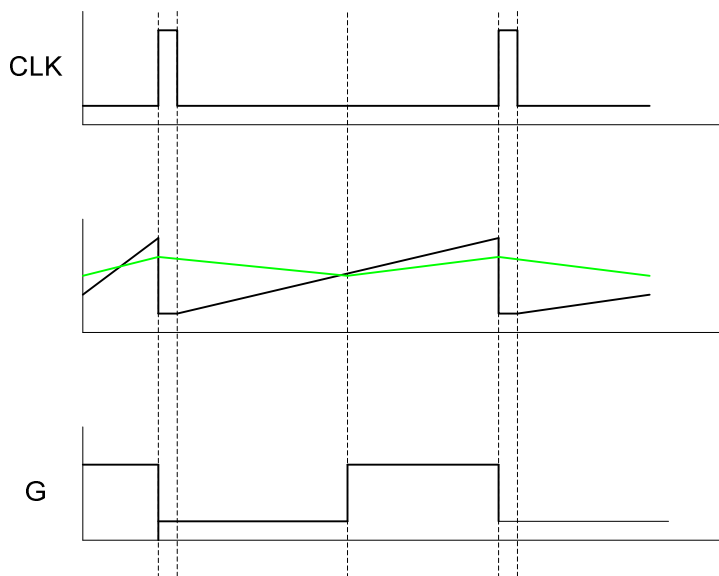

Figure 9: duty cycle modulation

Equation for Cso and RampDC:

$$V_{CS0} = G_{CS} * V_{CS}$$

Without RV

$$V_{Ramp DC} = f \left(\frac{1}{R_{FQ}} + \frac{V_{VCO}}{100} \right)$$

With RV

$$V_{Ramp DC} = f \left(\frac{1}{R_{FQ}} + \frac{V_{VCO}}{R_{RV}} \right)$$

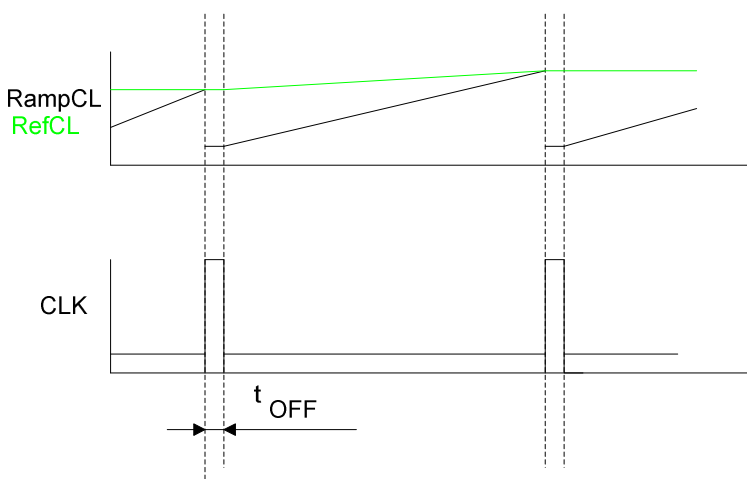
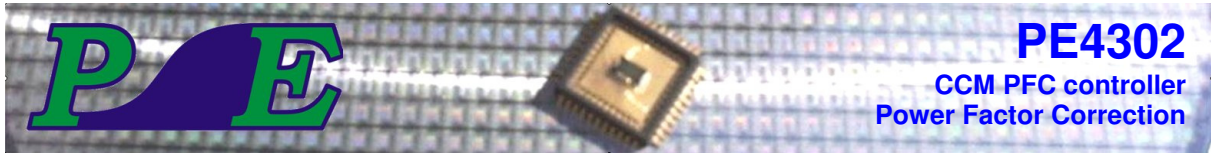

Figure 10: clock modulation

Equation for RefCL and RampCL:

$$V_{RefCL} = 0.3 + f(V_{VCO})$$

$$V_{RampCL} = f \left(\frac{1}{R_{FQ}} \right)$$



3 Interfaces

Pin	Pad	Interface	I/O	Function
1	1	VCO	I/O	Voltage Compensation
2	2	IN	I	Regulation Input
3	3	FQ	I/O	Frequency Adjustment
4	4	RV	I/O	Ramp Adjustment
5	5	VDD	I	Power Supply
6	6	G	O	Driver Output
7	7	GND	I	Power Ground
8	8	CS	I	Current Sense

4 Package

The PE4302 comes in an SOIC8 package.

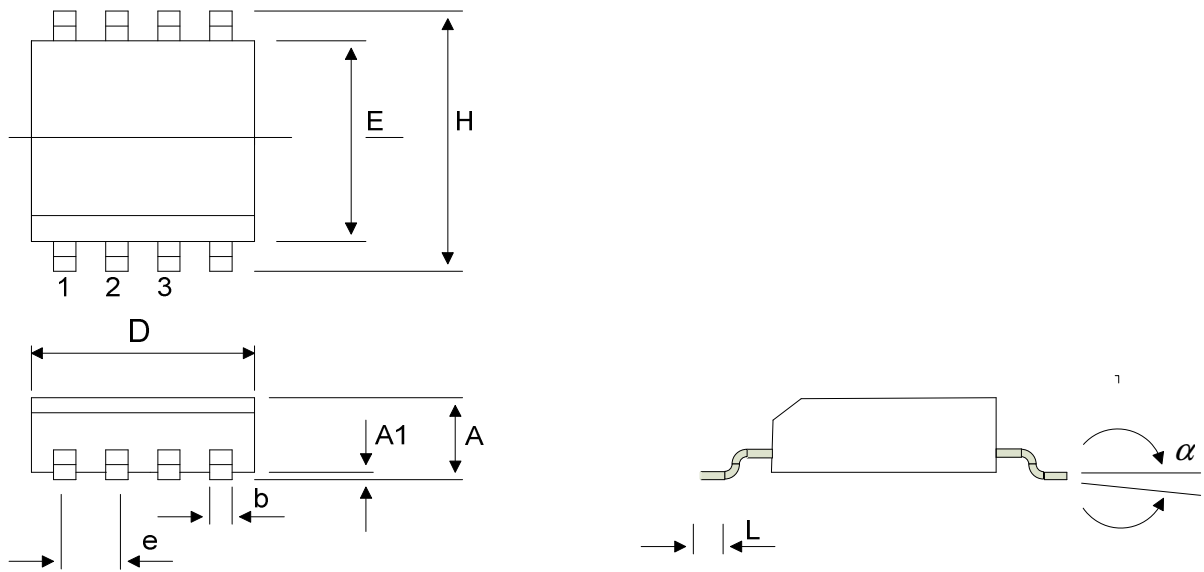

Dim.		D	E	H	A	A1	e	B	L	Copl	α
mm	min	4.80	3.80	5.80	1.35	0.10	1.27	0.33	0.40	0.10	0°
	max.	5.00	4.00	6.20	1.75	0.25		0.51	1.27		8°
inch	min	0.189	0.150	0.228	0.053	0.004	0.050	0.013	0.016	0.04	0°
	max.	0.197	0.157	0.244	0.069	0.010		0.020	0.050		8°

PE4302

**CCM PFC controller
Power Factor Correction**

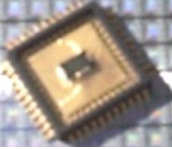

Contact Addresses

Germany

Stuttgart

Productivity Engineering
Process Integration GmbH
Behringstrasse 7
D-71083 Herrenberg
Germany
Phone.: +49 (0) 70322798 0
Fax: +49 (0) 70322798 29
Email: info@pe-gmbh.com

Dresden

Productivity Engineering GmbH
Branch
Sachsenallee 9
D-01723 Kesselsdorf
Germany
Phone.: +49 (0) 3520490 207
Fax: +49 (0) 3520490 270
Email: pfc.support@pe-icdesign.de

Important Notice

Productivity Engineering GmbH (PE) reserves the right to make corrections, modifications, enhancements, improvements, and other changes to its products and services at any time and to discontinue any product or service without notice. Customers should obtain the latest relevant information before placing orders and should verify that such information is current and complete. All products are sold subject to PE's terms and conditions of sale supplied at the time of order acknowledgment. PE warrants performance of its hardware products to the specifications applicable at the time of sale in accordance with PE's standard warranty. Testing and other quality control techniques are used to the extent PE deems necessary to support this warranty. Except where mandated by government requirements, testing of all parameters of each product is not necessarily performed. PE assumes no liability for applications assistance or customer product design. Customers are responsible for their products and applications using PE components. To minimize the risks associated with customer products and applications, customers should provide adequate design and operating safeguards. PE does not warrant or represent that any license, either express or implied, is granted under any PE patent right, copyright, mask work right, or other PE intellectual property right relating to any combination, machine, or process in which PE products or services are used. Information published by PE regarding third-party products or services does not constitute a license from PE to use such products or services or a warranty or endorsement thereof. Use of such information may require a license from a third party under the patents or other intellectual property of the third party, or a license from PE under the patents or other intellectual property of PE. Resale of PE products or services with statements different from or beyond the parameters stated by PE for that product or service voids all express and any implied warranties for the associated PE product or service and is an unfair and deceptive business practice. PE is not responsible or liable for any such statements.
© 2010 PE GmbH. All rights reserved.

All trademarks and registered trademarks are the property of their respective owners.

The project is funded in parts by the European fund for regional development (EFRE) and the state of Saxony.