



New power supply solutions for fluorescent energy saving lamps and LED lighting with PFC

G.Bannert, Application Engineer, PE IC Design GmbH

What is power factor correction (PFC) good for? PFC avoids apparent power being drawn from the power grid. This apparent power becomes larger as the phase shift between current and voltage gets larger due to more capacitive or inductive loads. Such load behavior can be observed with LED light stripes or very often with fluorescent lamps. This topic is generally neglected since the apparent power is not paid for by private utility customers whereas large enterprises already pay for it. This becomes increasingly important with the change towards new lighting sources that require electronic circuitry. Without this power factor correcting circuitry the power grid would be heavily loaded with apparent power. Also, it is not to be forgotten that this power has to be generated in power plants as well. Upon a closer look, this makes the energy saving light sources not so effective any more.

For this reason governmental regulations in some countries have been in place for a couple of years now, but not world wide, e.g. the EN61000-3-2. Common incandescent lamps (with a power factor of one) will disappear from the European Union within 2 years. Instead there will be billions of LED and fluorescent lamps. They are much more energy efficient but they require electronic circuitry to operate with an 110V or 220V power supply. This circuitry is typically within the housing of the light sources and so is not visible or noticeable to the user. All of these electronic circuits have in common a rectifier and reservoir or smoothing capacitor on the power supply side. The capacitor is charged to the peak voltage every half cycle period. The charging current depends on how much the capacitor has been discharged by the load. This causes the current not to follow the voltage and in turn to cause a power factor of less than one. Following the rectification step is the circuitry for the special lighting source. With LEDs it is a DC/DC converter. With fluorescent lamps it is an electronic ballast circuit and a resonant tank circuit to ignite and run the lamp. This circuit as well as the DC/DC converter runs at a higher frequency and additionally affects the power factor. For Power LEDs the power factor drops to 0.5 and for fluorescent lights it drops to 0.6. The federal regulations require power factor correction for lighting applications above power levels of 25 watts for a single source. These light sources typically have far less wattage when considered alone (3Watt LED/7Watt Fluorescent light bulb), but who in the world has only one of these in their chandeliers? Now if the whole European Union will replace all lights one can imagine what that means. None of the currently available energy saving light bulbs have power factor correction implemented. So it is to be expected that the federal regulations will have to account for these disharmonies (EN61000-3-2, class C).

Expecting this to happen, PEGmbH has developed very efficient electronic solutions for this problem. PE has developed PFC ICs with an incomparable low power consumption (PE4201 and PE4301). They cover a very wide power application range.

Active PFC is based on the principle to make the input current exactly follow the input voltage in such a way that very few frequency harmonics and phase shifts can be observed. This can be done by charging a capacitor with a voltage above the peak voltage of the input voltage (AC line voltage multiplied by $\sqrt{2}$). This capacitor has enough energy that can be used to adapt the non linear load to draw linear current from the power line.

The PE4301 with CCM PFC has been designed for larger loads. The PE4201 (CRM/DCM PFC) is the more ideal candidate for lighting applications up to 30 watts. A miniaturized application has been developed at PEs application lab to fit into an E27 fluorescent lamp besides the already installed electronic ballast. The transformer is optimized for a 22 watt fluorescent lamp that achieves an efficiency of more than 90% along with a very small shunt resistor, a special feature of the chip family. The power factor is higher than 0.95. By optimizing the transformer it can easily be adapted to fit smaller loads achieving the same performance, even at 7watt loads. The form factor can be reduced

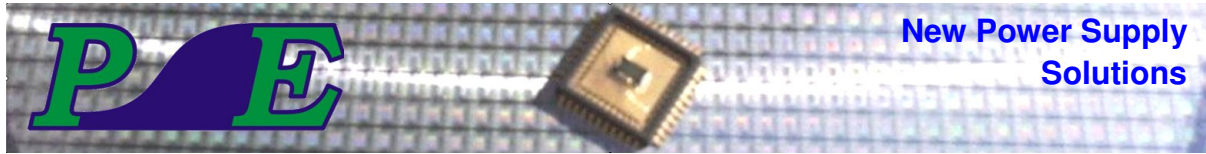

even more by using a planar transformer. The output voltage of the PFC circuit has been set at 330-335 volts. This is just a few volts above the peak voltage of the rectifier smoothing capacitor and the electronic ballast can be used unchanged. The PFC circuitry is limited to the transformer, a small FET, the PFC chip, one fast diode and a few passive devices (0805 sizes).

With Power LEDs the problem is different. The high DC voltage after power factor correction has to be converted with a DC/DC converter into a lower voltage or even better a constant current. For physical reasons power factor correction and voltage transformation can not be done with just one transformer. The output voltage of such a circuit would have a strong AC 100Hz fluctuation (potentially even visible) and the power factor would go down to 0.7 or below, which puts this principle in question. So a commonly used DC/DC conversion seems a more feasible approach. The PFC circuitry can be used almost unchanged from the former mentioned fluorescent light solution. But the application engineers at PEs lab went one step further. To do so required analyzing the requirements.

- The LED DC/DC converter has to fulfil the following requirements:
- PFC output voltage ripple has to be smoothened
- a highly constant, input voltage independent of the output current has to be provided
- galvanic separation has to be achieved
- high efficiency so that the character of an energy saving power LED will not be compensated by other losses
- output over-voltage protection if the load is being turned off
- potentially dimming of the LEDs

Interestingly the PE engineers came to the conclusion that a simple solution also makes use of a second PE4201 chip. The IC has very low power consumption by itself. Most of the current of the chip goes into the driven FET gate. The voltage regulation is very precise, the current shunt can be very low resistance which again causes very little power loss. Additionally, the current regulation input can be used for dimming the LEDs without additional PWM noise.

The flyback converter principle can be used for galvanic separation. A very low $R_{DS(on)}$ FET is being used to preserve energy and keep self heating low, which is especially important within the housing of such a lamp. For the LED application below 10watt a continuous current type FET rated below 500mA can be used. Due to the flyback converter connected to the output of the PFC a 600 volt type is required. Since the input voltage is almost constantly at 330 volts due to the PFC circuitry, only the current for the LEDs has to be controlled.

Thus the secondary side of the flyback converter does not have to be controlled by an optic-coupler which reduces the BOM (see figure 1).

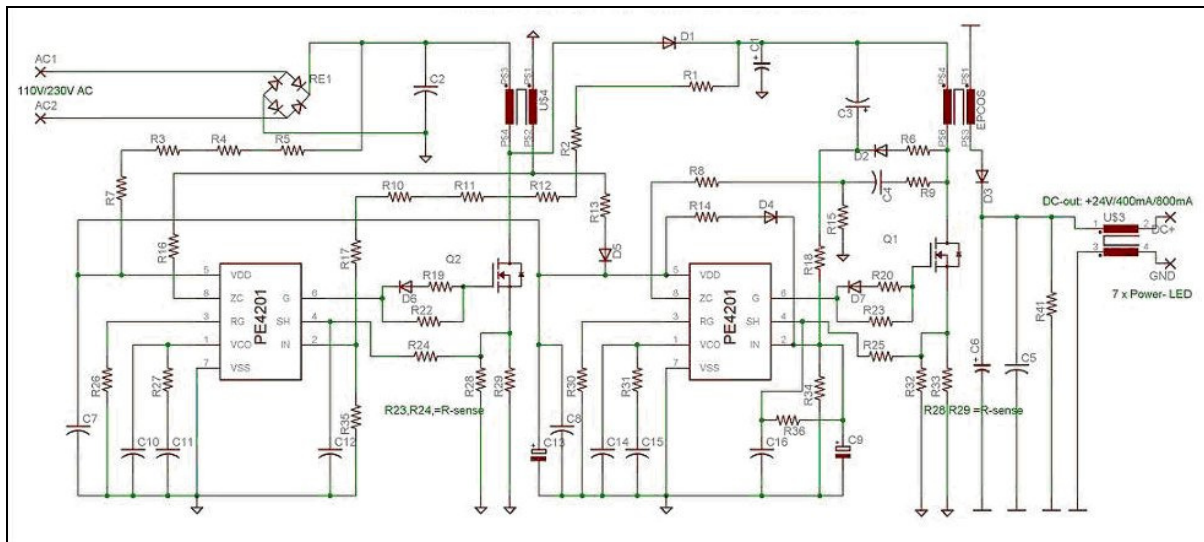
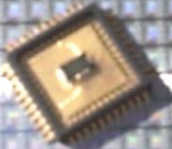

Figure1: Circuit Diagram for the PFC-LED-power supply

The transformer is optimized such that the LED chain voltage is set at max current for the number of LEDs in the chain which results in max brightness. The secondary rectifier diode has to be chosen for low voltage and fast recovery. This performance directly impacts the efficiency. The PE4201 has three control loop inputs that can be used for a DC/DC converter application. Pin8 (ZC) serves to observe the energy flow of the transformer core and optimizes the on-time of the FET (comparable to the PFC application). Pin4 (SH) serves to control the current through the FET and here it indicates the current through the LEDs as well. Pin2 (IN) is used for output voltage regulation in PFC application but serves an over-voltage output protection in case of no load. Without a load the output voltage will increase and so the induced voltage on the turned off drain of the FET will raise. Pin 2 provides the information into the chip (Vovlp that controls the converter in burst mode).

The efficiency of the DC/DC converter is about 80%. The efficiency of the PFC is about 90%. The total efficiency that can be achieved is 72% for both circuits in this application. Since the PFC is placed before the DC/DC converter filtering towards the power supply can be minimum compared to a direct connect of a typical DC/DC converter for LEDs.

If desired the current control loop of the converter can be used for dimming the LED brightness down to 50%. By using an optic coupler this dimming can also be with galvanic separation, depending on the application and location of the LED light source.

The whole circuitry can be adapted to any input voltage, 80-120volts or 190-240 volts and can achieve the measured efficiency and power factor under both conditions. It would also be possible to have one solution running from 80-240 volts, though with compromises for power factor and efficiency but is not recommended for this reason.

The power factor without input filter is measured at 0.99 (figure 2,3,4). The use of an input filter causes a phase shift again and so reduces the power factor. An optimum for EMI requirements and power factor has to be applied here.

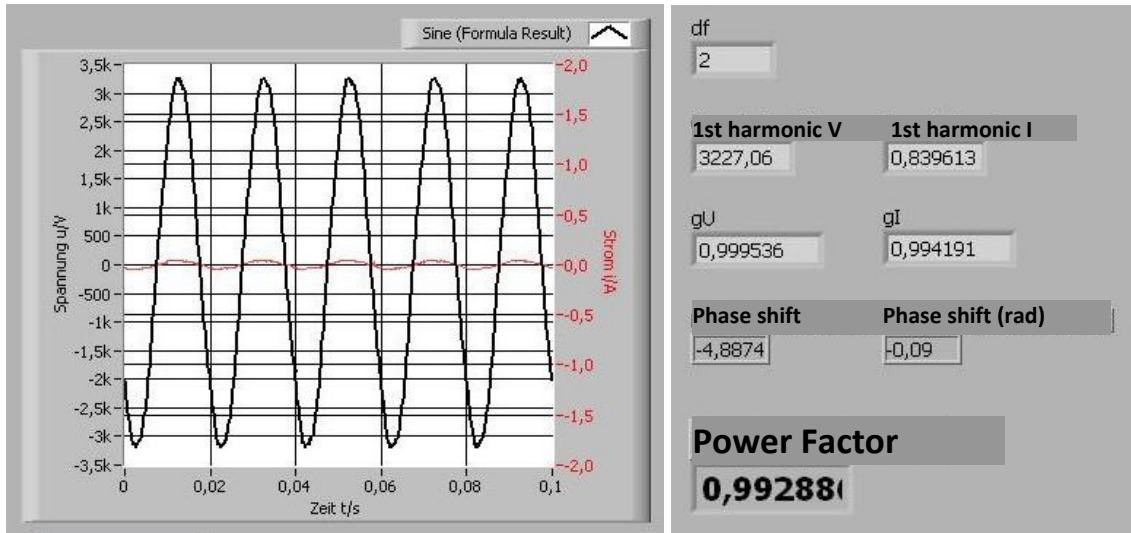

Figure2: PF-corrected current and voltage diagram

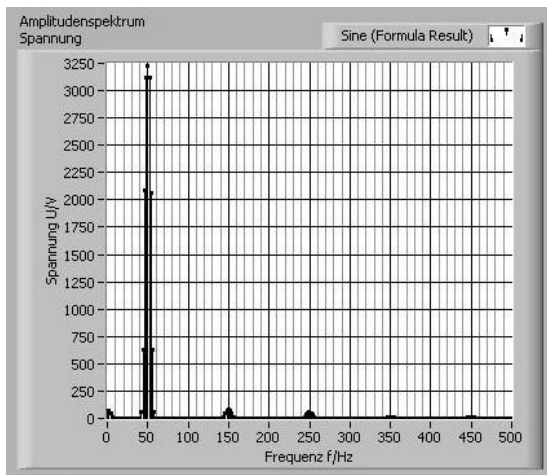

Figure.3: V-Amplitude Spectrum

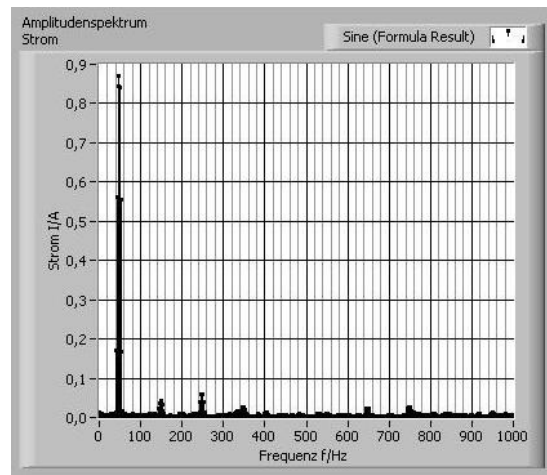

Figure.4: I-Amplitude Spectrum

Additional application notes for the PE PFC ICs can be found at the web site

www.powerfactorcorrection.de