

General

The PE4202 is a high precision wide input range PFC controller IC for active power factor correction converters.

The IC operates in CRM (Critical conduction Mode) with voltage mode PWM (Pulse Width Modulation) control and in DCM (Discontinuous Conduction Mode) under light load condition.

Using PE's solution for power factor correction, manufactures of switched mode power supplies (SMPS) are able to realize power supplies that are smaller, more cost effective and safer than before.

Motivation

The trend of further increasing functionality of electronic devices and equipment is set forth with higher speed. Developers of switched mode power supplies (SMPS) are faced with requirements for system miniaturization, while concurrently the technical capabilities and power consumption of the equipment is increasing. With its new Power Factor Correction (PFC) product family, PE addresses the special requirements of the SMPS industry for:

- efficiency of switched mode power supply with PFC
- minimized heat development
- reduced total system cost
- product safety

Advantages of PE innovations over competition products

Productivity Engineering offers the PE4202, an wide input range analog PFC controller featuring CRMode with voltage controlled PWM and DCMode at light load condition. Compared to competition products, the PE4202 offers features and parameters, which allow the most cost efficient solution for switched mode power supply manufactures and set a high value on product safety. The advantages of the PE4202 in detail:

- ✓ lowest power consumption (typical) in start-up-phase : 2 μ A
stand-by-phase : <100 μ A
active-operation-phase : 250 μ A
 - *none of comparable products presents such outstanding data*
 - *reduced thermal power loss*
 - *smaller housing options*
 - *no need for extra power supply (PFC IC) in stand-by*
- ✓ most precise reference: 2.47 .. 2.51V
 - *best-in-class accuracy (< \pm 1%)*
 - *no need for expensive trimming of output voltage*
- ✓ best over-current level detection: 0.24V
 - *smallest power loss over sense resistor*
 - *internal noise reduction*
 - *reduced thermal power loss*
 - *cost-effective external components*
- ✓ broad operating voltage: 7..25V
 - *easier to handle from system perspective*
 - *saving of discrete components (diodes, capacitors)*
 - *Gate voltage (MOSFET) limited to a maximum of 11V*
- ✓ large StartUp/LockOut hysteresis: 11..16V
 - *need smaller capacity on VDD*
- ✓ implemented mains voltage capture
 - *no need for external voltage divider*

Value Proposition

By using PE's chip solution for power factor correction (PE4202), customers benefit from different advantages:

- Saving of external components reduces cost of the system bill-of-material
- Less power consumption allow for a smaller form factor and reduces the measures for equipment cooling, which translates into cost savings again
- Highest precision and best-in-class power loss numbers generate a competitive advantage
- No need for extra power supply (PFC IC) in stand-by mode saves system cost
- A second voltage reference addresses safety requirements and prevent the system from total breakdown

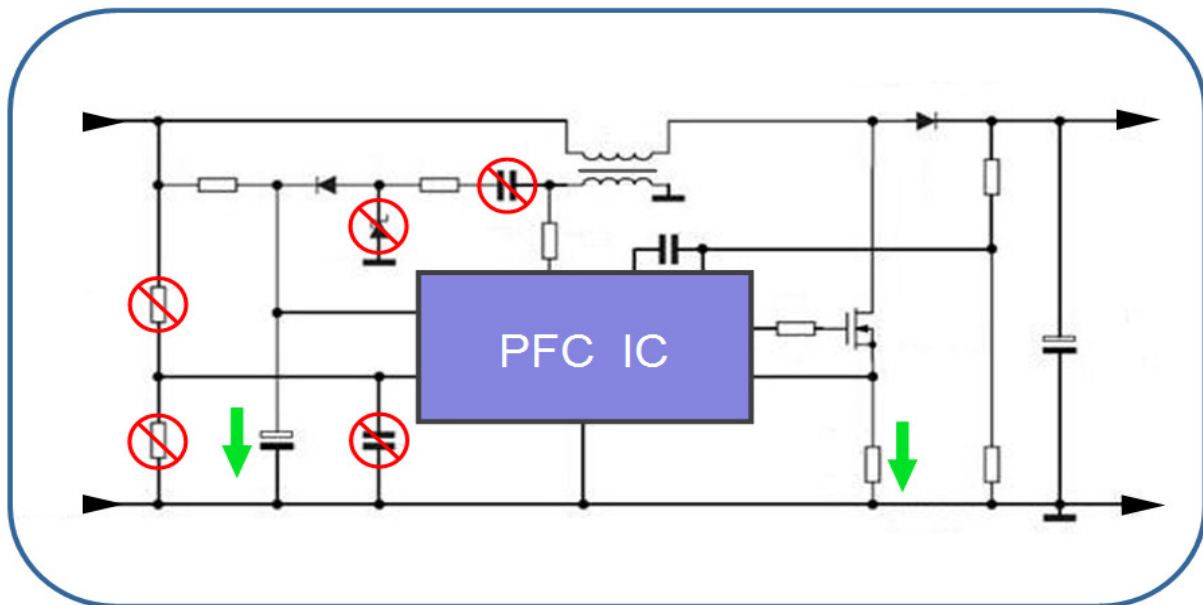

Schematic of a typical PFC application and saving potential by using a PE4202

Important Notice

Productivity Engineering GmbH (PE) reserves the right to make corrections, modifications, enhancements, improvements, and other changes to its products and services at any time and to discontinue any product or service without notice. Customers should obtain the latest relevant information before placing orders and should verify that such information is current and complete. All products are sold subject to PE's terms and conditions of sale supplied at the time of order acknowledgment. PE warrants performance of its hardware products to the specifications applicable at the time of sale in accordance with PE's standard warranty. Testing and other quality control techniques are used to the extent PE deems necessary to support this warranty. Except where mandated by government requirements, testing of all parameters of each product is not necessarily performed. PE assumes no liability for applications assistance or customer product design. Customers are responsible for their products and applications using PE components. To minimize the risks associated with customer products and applications, customers should provide adequate design and operating safeguards. PE does not warrant or represent that any license, either express or implied, is granted under any PE patent right, copyright, mask work right, or other PE intellectual property right relating to any combination, machine, or process in which PE products or services are used. Information published by PE regarding third-party products or services does not constitute a license from PE to use such products or services or a warranty or endorsement thereof. Use of such information may require a license from a third party under the patents or other intellectual property of the third party, or a license from PE under the patents or other intellectual property of PE. Resale of PE products or services with statements different from or beyond the parameters stated by PE for that product or service voids all express and any implied warranties for the associated PE product or service and is an unfair and deceptive business practice. PE is not responsible or liable for any such statements.
© 2010 PE GmbH. All rights reserved.

All trademarks and registered trademarks are the property of their respective owners.

The project is funded in parts by the European fund for regional development (EFRE) and the state of Saxony.