

# PE3001 UHF Logger

Application Note  
Connect to  $\mu\text{C}$  via SPI



## General

This proposal presents a possible principal application to connect the PE3001 with any  $\mu\text{C}$  via SPI.

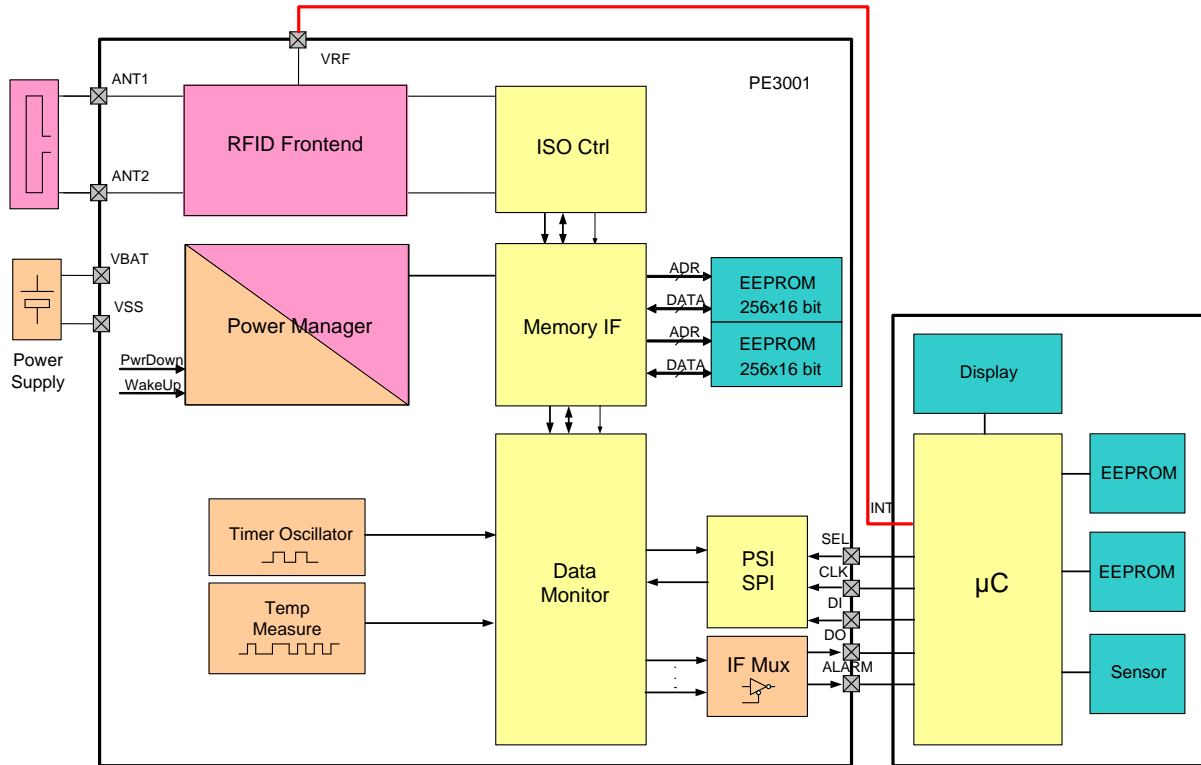

It is important to design a zero load connection between VRF and INT. VRF is load limited and must not be tight to a high voltage potential, e.g. on a pull-up port. Typically a source follower or Schmitt-trigger can be used between VRF and INT. The microcontroller usually has a CMOS input, which in this case can also be driven directly.

The following procedure is possible to communicate through the RFID interface to a  $\mu\text{C}$ :

1. Define a range of addresses in USER-Bank (e.g. TRANS0\_F) to read and write transferred data.
2. Define an address (e.g. COMM) in USER-Bank as communication process interface:
  - e.g.: 01h read data via RFID from USER-Bank (TRANS0\_F),
  - 02h write data via RFID to USER-Bank (TRANS0\_F),
  - 03h data via RFID transferred to USER-Bank (TRANS0\_F),
  - 04h data via RFID transferred from USER-Bank (TRANS0\_F),
  - 05h read data via SPI from USER-Bank (TRANS0\_F),
  - 06h write data via SPI to USER-Bank (TRANS0\_F),
  - 07h data via SPI transferred to USER-Bank (TRANS0\_F),
  - 08h data via SPI transferred from USER-Bank (TRANS0\_F),
  - 00h transfer ended or no transfer necessary,
  - ... what ever more is necessary for internal communication



### 3. Procedure for Communication:

- Data to  $\mu$ C from RFID
  - RFID write data to TRANS0\_F
  - RFID write 03h on address COMM in USER-Bank
  - $\mu$ C if VRF=0 (red line on block diagram, Interrupt detected), read address COMM via SPI
  - $\mu$ C if data on COMM = 03h, read TRANS0\_F, write 08h on address COMM in USER-Bank
  - RFID procedure was repeated or RFID write 00h to COMM for transfer end
- Data to RFID from  $\mu$ C
  - $\mu$ C write data to TRANS0\_F via SPI
  - $\mu$ C write 07h on address COMM in USER-Bank
  - RFID polling read address COMM
  - RFID if data on COMM = 07h, read TRANS0\_F, write 04h on address COMM
  - $\mu$ C procedure was repeated or  $\mu$ C write 00h to COMM for transfer end
- there are more possible transfer procedures for a handshake communication between RFID and  $\mu$ C

# PE3001 UHF Logger

Application Note  
Connect to  $\mu$ C via SPI



## Contact Addresses

### Germany

#### Stuttgart

Productivity Engineering  
Process Integration GmbH  
Behringstrasse 7  
D-71083 Herrenberg  
Germany  
Phone.: +49 (0) 70322798 0  
Fax: +49 (0) 70322798 29  
Email: info@pe-gmbh.com

#### Dresden

Productivity Engineering GmbH  
Branch  
Sachsenallee 9  
D-01723 Kesselsdorf  
Germany  
Phone.: +49 (0) 3520490 207  
Fax: +49 (0) 3520490 270  
Email: info@pe-gmbh.com

## Important Notice

Productivity Engineering GmbH (PE) reserves the right to make corrections, modifications, enhancements, improvements, and other changes to its products and services at any time and to discontinue any product or service without notice. Customers should obtain the latest relevant information before placing orders and should verify that such information is current and complete. All products are sold subject to PE's terms and conditions of sale supplied at the time of order acknowledgment. PE warrants performance of its hardware products to the specifications applicable at the time of sale in accordance with PE's standard warranty. Testing and other quality control techniques are used to the extent PE deems necessary to support this warranty. Except where mandated by government requirements, testing of all parameters of each product is not necessarily performed. PE assumes no liability for applications assistance or customer product design. Customers are responsible for their products and applications using PE components. To minimize the risks associated with customer products and applications, customers should provide adequate design and operating safeguards. PE does not warrant or represent that any license, either express or implied, is granted under any PE patent right, copyright, mask work right, or other PE intellectual property right relating to any combination, machine, or process in which PE products or services are used. Information published by PE regarding third-party products or services does not constitute a license from PE to use such products or services or a warranty or endorsement thereof. Use of such information may require a license from a third party under the patents or other intellectual property of the third party, or a license from PE under the patents or other intellectual property of PE. Resale of PE products or services with statements different from or beyond the parameters stated by PE for that product or service voids all express and any implied warranties for the associated PE product or service and is an unfair and deceptive business practice. PE is not responsible or liable for any such statements.  
© 2010 PE GmbH. All rights reserved.